

Leica DM8000 M & DM12000 M

See More, Detect Faster – Higher Productivity

Convincing Technical Details

Living up to Life

Leica

MICROSYSTEMS

High-throughput Inspection Systems

Inspection, process control and defect analysis of wafers or LCDs and TFTs has to be fast, accurate and ergonomic. The Leica DM8000 M and DM12000 M optical inspection microscopes provide an innovative yet cost-effective system solution for mastering present and future manual inspection challenges with confidence. Beside extreme large overview capabilities and high resolution optics these systems are incorporated in a highly ergonomic design with fully integrated LED illumination allowing the sample to be illuminated from different angles.





Larger field of view for faster inspection

The Leica DM8000 M and the Leica DM12000 M feature an integrated macro mode, which gives you four times the field of view of conventional scanning objectives. Seeing more means faster throughput.

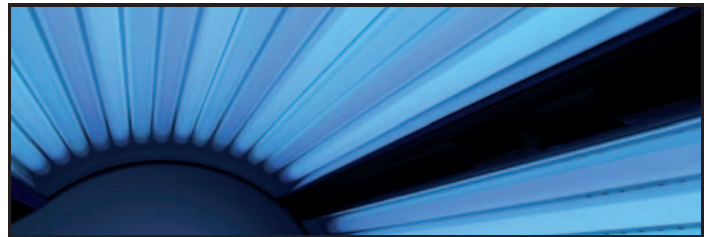

Highest resolution from every angle

The new Oblique UV (OUV) mode combines oblique illumination with UV light, which enables you to view a sample in high resolution from any angle – and enhances the accuracy of the inspection results.



Higher quality due to ergonomic design

An ergonomic design enables users to work in comfort, enhancing their performance and ultimately improving the quality of their work. The Leica DM8000 M/DM12000 M are specifically designed to provide comfort for long hours at the microscope, and are intuitively operated and easy to adapt to different users' microscopy skill levels.



LED illumination for a cleaner environment

The LED illumination integrated in the Leica DM8000 M/DM12000 M optimizes the airflow and creates a cleaner cleanroom. With their long lifetimes and low power consumption, LEDs also have a lower cost of ownership.

Optic – Excellent Image Quality

To achieve fast and reliable results during manual inspection within a very short time, the optical performance of the microscope is a key element. With the Leica DM8000 M and DM12000 M, Leica Microsystems has developed a series of innovative features that support the operator in completely new ways.

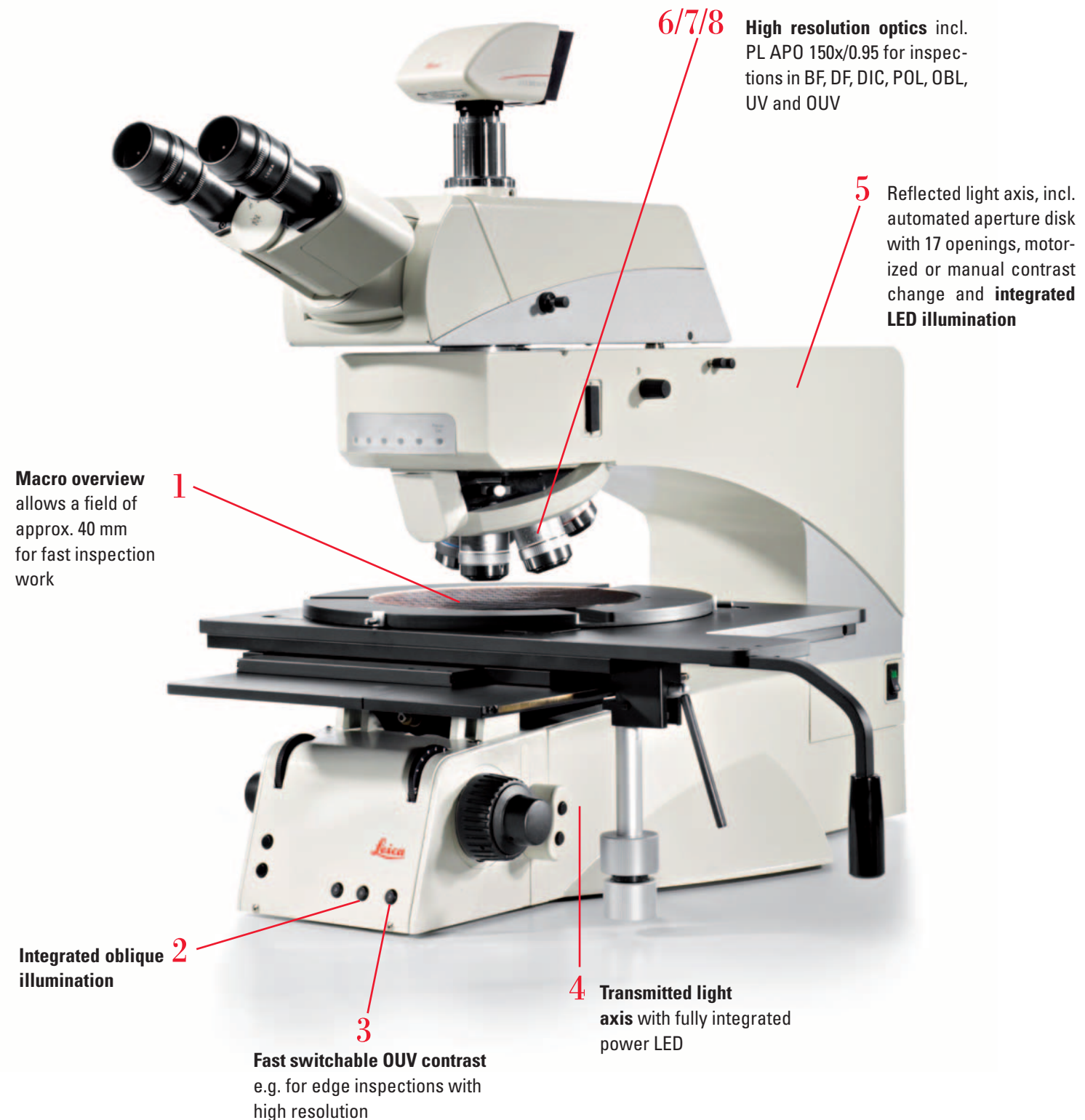

1. Macro Overview

In the motorized versions of the Leica DM8000 M and DM12000 M the micro/macro option for rapid scanning of large components can be integrated. The macro objective, which is fully parfocal with all other inspection objectives, captures an object field of approx. 40 mm on the sample – that's almost four times more than with conventional scanning objectives. With the Leica macro mode you detect defects that are invisible using conventional light microscopes, such as insufficient development at the edge or within the center of a wafer. Uneven radial film thicknesses are made visible using the macro overview mode.

The entire scan area can be accurately checked for possible defects in a fraction of the time. If you want to take a closer look, simply press a single button to switch from macro to micro mode and inspect the defect in the required contrast mode.

2. Integrated Oblique Illumination

For a quick inspection of edges, e.g. of transparent films or solar cells, the oblique illumination is integrated with every Leica DM8000 M and DM12000 M. By pressing the OBL button, oblique illumination is activated and the operator can decide which deviation angle α (see picture 2) of the beam path is applied to inspect the sample in the best way – fast, reliable, and with topographic information. The oblique illumination is combined with visible light contrast modes such as BF or DIC, but also with UV light in the OUV mode.

3. Fast Switchable UV and OUV Contrast

Achieving a higher resolution of the sample image is done with a single button click using the Leica DM8000 M and DM12000 M. Pressing the UV button the visible light is cut and the sample is illuminated in less than a second with UV light of 365 nm wavelength, thus reducing the resolvable structure sizes down to 0.14 μm . Just one additional button click gives a completely new visual experience – the OUV mode, an adjustable UV illumination beam that allows high resolution edge inspection, for example.

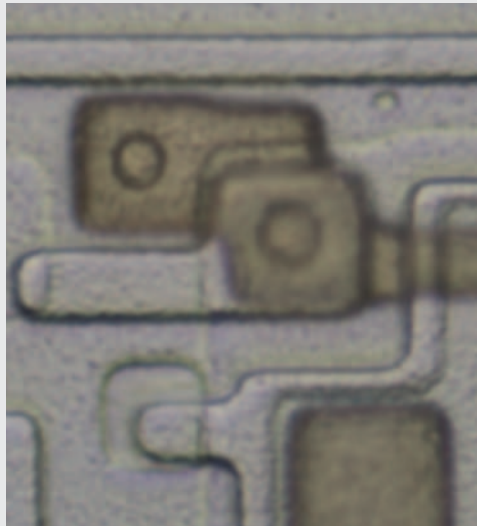

PL FLUOTAR 100x/0.90 – **brightfield**

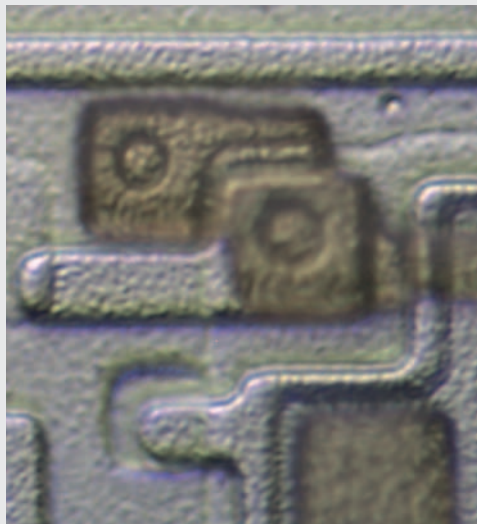

PL FLUOTAR 100x/0.90 – **oblique illumination**

1.

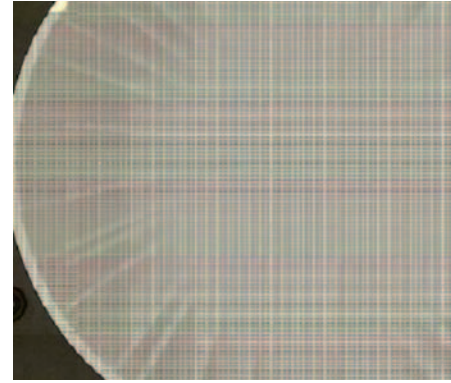

With the Leica macro mode, you detect defects that are invisible using conventional light microscopes, such as insufficient development at the edge.

2.

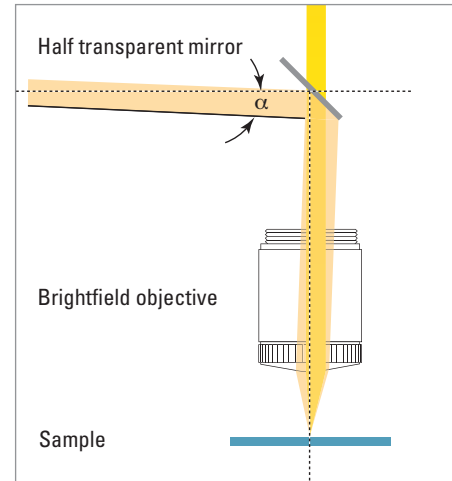

Edges of transparent layers are inspected using the oblique illumination mode.

3.



A single button click switches from visible to UV light within 1 second.

5.



The illumination with powerful LEDs is fully integrated with the Leica DM8000 M and DM12000 M stands.

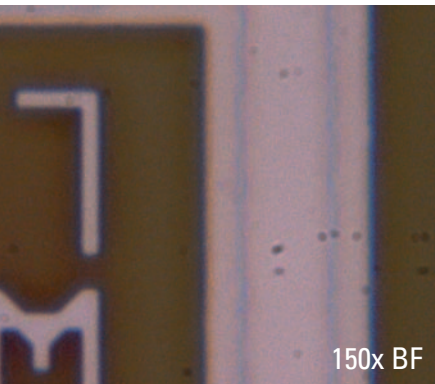

150x BF

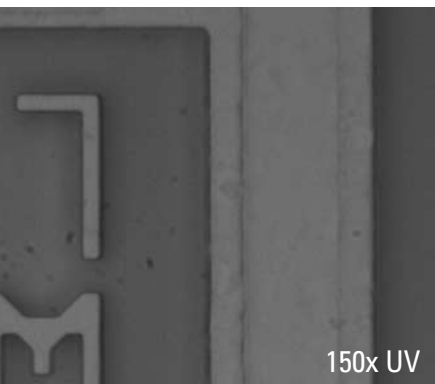

150x UV

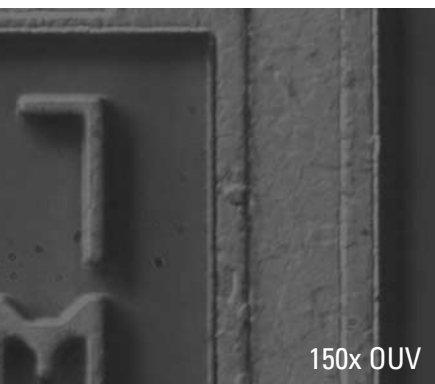

150x OUV

4. Transmitted Light Axis

The transmitted light axis (TL) is equipped with a fully integrated LED illumination in the same way as the reflected light axis. With the integrated LED illumination samples such as transparent LCD panels are inspected with brightfield or with polarized light.

For high precision inspection of semitranslucent devices, a single button click is enough to activate reflected light (RL) and transmitted light (TL) simultaneously. Intensity, aperture, and even contrast mode can be switched independently for RL and TL. To inspect microscratches, for example, you can have the OBL mode in RL and polarized light in TL at the same time and adjust intensity and aperture of both axes separately. This saves time during inspection and allows additional information to be gathered from the sample.

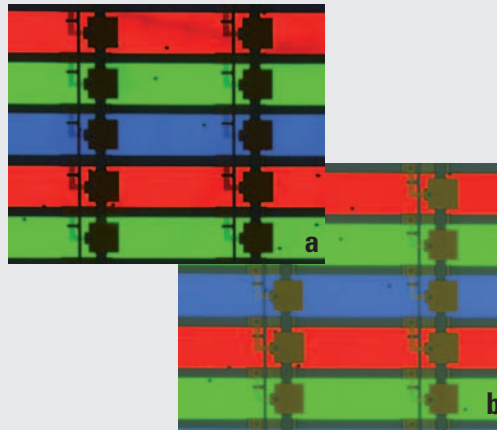

LCD panel in (a) transmitted light only and (b) transmitted and reflected light simultaneously

5. Fully Integrated LED Illumination

The LED illumination is integrated within the microscope. Without a lamphousing in the way, there is an optimal airflow around the microscope. A clean solution for the cleanroom. The powerful LEDs with a color temperature of 4,000 K have a very long lifetime of up to 25,000 hours yet extremely low power consumption with the highest illumination power. For BF, DF or DIC in reflected light the powerful LEDs are used in the same way as for UV illumination or transmitted light inspections. The long lifetime of the LEDs reduces the downtime of the instrument significantly as there is no need for bulb exchange. Keep your environment clean while saving money and increasing productivity at the same time.

6. Multi-functional Plan APO 150x/0.90

Top of the line of the inspection objectives is the multi-functional Plan APO 150x/0.90 objective. With this single objective, which is fully parfocal with all other inspection objectives, the user works in BF, DF, DIC, POL, OBL, UV and OUV.



Multi-functional objective: HCX Plan APO 150x/0.90

7. In-depth Darkfield

Increased intensity and a higher resolution combined with a longer working distance characterize the new in-depth darkfield Plan FLUOTAR objectives. Compared to conventional darkfield objectives, the image brightness has improved significantly while the working distance has nearly doubled, thus keeping the sample safe and providing even more image information.

8. Dedicated Inspection Objective Series

To attain faster and more accurate sample analysis without damaging the sample, the PL FLUOTAR LWD and PL APO objectives series are used. While the inspection objectives of the PL FLUOTAR LWD series feature extra long working distances for sample protection, the high resolving power and high image sensitivity of the PL APO objective allow fast, precise analysis and decisions on the results viewed.



Dedicated objectives for the inspection of microelectronic components

8.

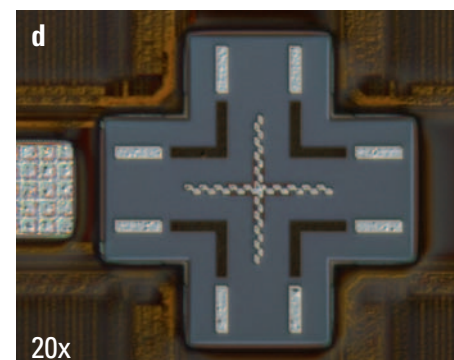
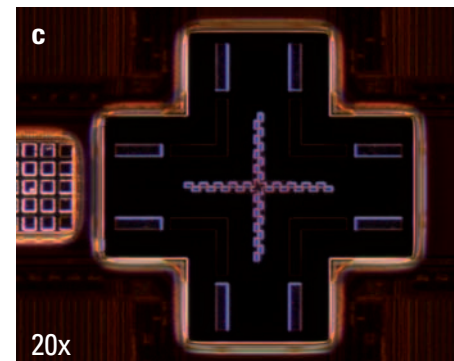
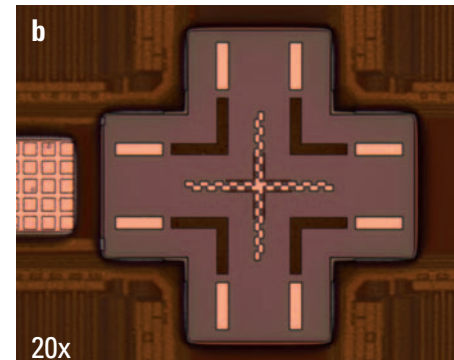
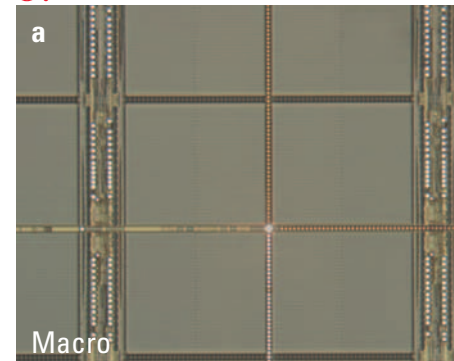

Quick macro mode scan (a), brightfield (b), in-depth darkfield (c), differential interference mode (d). It takes less than a second to switch contrast modes.

Ergonomics – Clean Design

The Leica DM8000 M and DM12000 M inspection microscopes make routine work as comfortable and effortless as possible. Using these microscopes, which are specifically designed for inspection of microelectronics parts, only a few moments are required to adjust the instrument to the operator's seated height, posture, arm length, and hand size. Microscopy has never been more comfortable, enabling fast and precise inspection work.

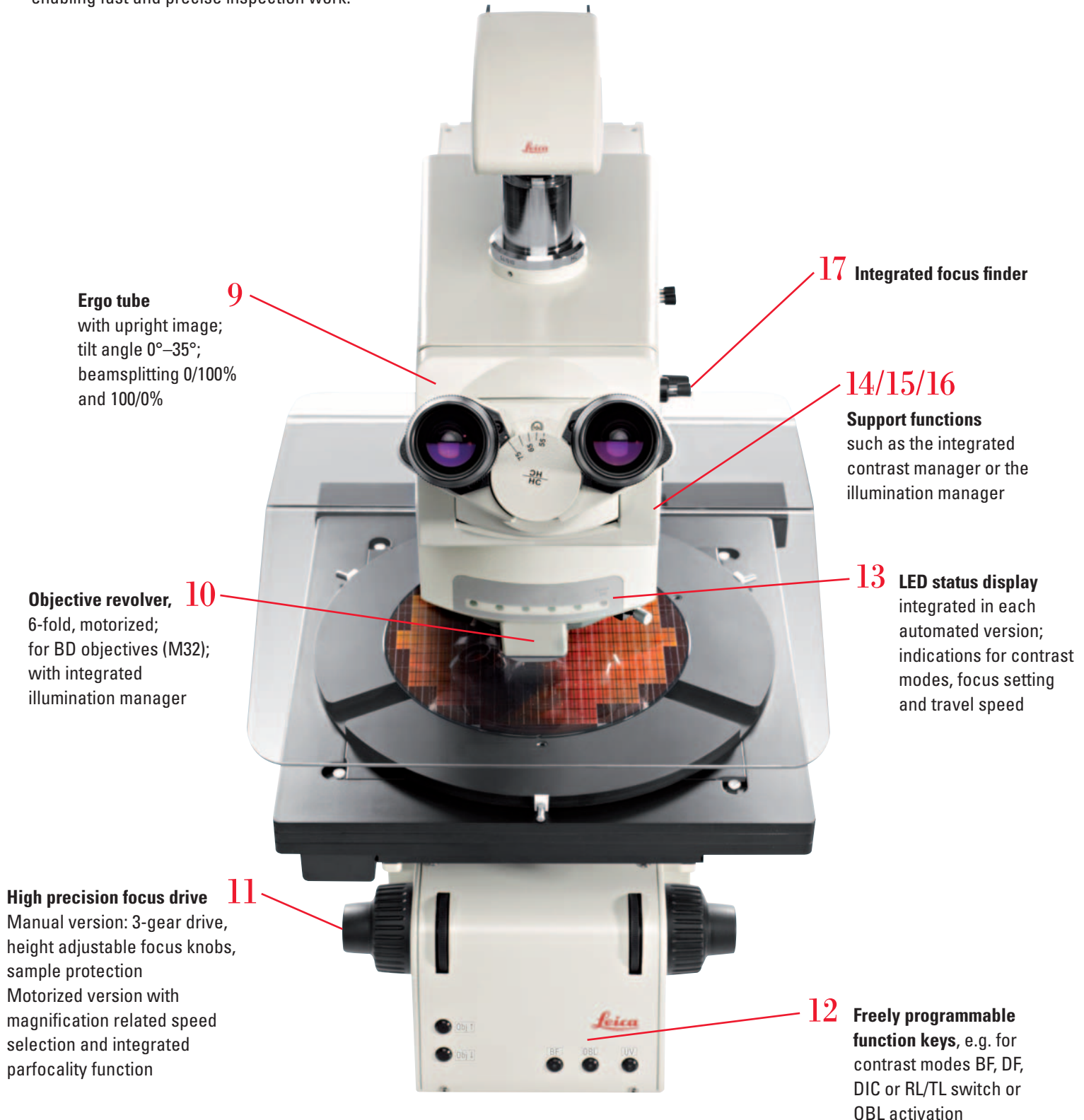

Ergo tube
with upright image;
tilt angle 0°–35°;
beamsplitting 0/100%
and 100/0%

9

17 Integrated focus finder

14/15/16

Support functions
such as the integrated
contrast manager or the
illumination manager

Objective revolver,
6-fold, motorized;
for BD objectives (M32);
with integrated
illumination manager

10

13 LED status display
integrated in each
automated version;
indications for contrast
modes, focus setting
and travel speed

High precision focus drive
Manual version: 3-gear drive,
height adjustable focus knobs,
sample protection
Motorized version with
magnification related speed
selection and integrated
parfocality function

11

**12 Freely programmable
function keys,** e.g. for
contrast modes BF, DF,
DIC or RL/TL switch or
OBL activation

9. Upright Image Ergo Tube

With an adjustment angle from 0–35°, the upright image ergo tube fits any body shape and delivers in the version with a 100/0% (eyepiece/camera) and 0/100% or in the version 0/100% and 50/50% excellent images at both the eyepieces and the camera port. For UV and VIS imaging a separate upright image ergo tube is used, ensuring that no UV light passes the eyepieces.

10. Fast, Smooth-moving Objective Nosepiece

Overview inspections with the macro objective, edge inspection with a 5x or 10x magnification or review of small details with 100x or 150x magnification – all these steps of an exemplary inspection workflow often need to be performed in less than a minute, requiring highest parcentration accuracy. Especially developed for use in a cleanroom environment, the sealed 6-fold BD (M32) objective revolver integrates two separate motors, one for rotation and the other for fine movement, resulting in fast yet completely smooth movement that is an audible sign of its long-life quality. Comfortable use even with cleanroom gloves is ensured by easy to reach control buttons at the front of the instrument.

11. Focus Drive

The manual Leica DM8000 M and DM12000 M inspection microscopes feature a precision 3-gear system, a sample protection stop, a torque adjustment mechanism, and height-adjustable focus knobs. A total travel range of 35 mm can be adjusted in the coarse mode, the fine mode or the super-fine mode. The automated Leica DM8000 M and DM12000 M inspection microscopes are outfitted with a motorized focus drive having a travel range of 35 mm with a minimal step size of 3.6 nm and a maximum speed of 5 mm/sec. The electronically controlled focus drive has five speeds. Parfocal compensation can be set easily for all objectives, which eliminates the need for individual refocusing after objective change.

Height-adjustable Focus Knobs

No two hands are alike. And so the manual Leica DM8000 M and DM12000 M microscope versions enable every hand to rest on the table while reaching the focus knobs in complete comfort. The vertical position of the focus knobs can be precisely adjusted to fit the individual user's hand. This prevents hand, arm, and shoulder tension and ensures a comfortable, fatigue-free grip – without additional arm supports.

9.



Tilting trinocular tube with upright image to suit any viewing position

10.



Fast, smooth and reliable long-life objective change

11.



Height-adjustable focus knobs fit every operator's hand size.

12.



The easy to reach variable function buttons allow a reduction of inspection time of up to 10%.

13.

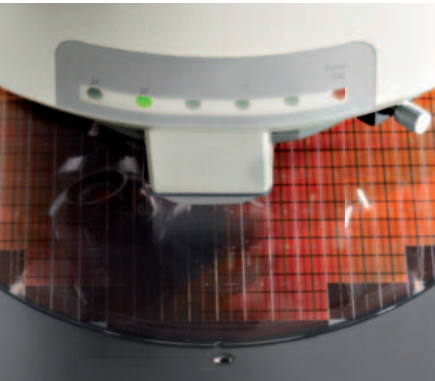

Easy to read feedback with the integrated LED display

14.



The 17-position aperture disk allows 100% reproducibility.

12. Programmable Function Buttons

Inspection routines can differ from sample to sample. With the introduction of programmable function buttons, the speed of operation can be significantly increased without harming the quality of inspection. Three of the conveniently arranged buttons with integrated feedback LED are located on the front of each Leica DM8000 M or DM12000 M microscope. Semi-motorized or motorized stands feature 4 additional buttons behind the focus knobs to provide easy, fast access to the functions used most. Additional function buttons are available on the external Leica STP6000 SmartTouch Panel, on the joystick or on the Leica SmartMove remote control.

13. LEDs Displaying Microscopy Status

Immediate feedback of the current contrast mode, the focus setting or the x, y, z travel speed (coarse or fine mode) is provided for the user of a motorized and semi-motorized Leica DM8000 M or DM12000 M microscope with the integrated LED status display.

14. Motorized Aperture Diaphragm

All Leica DM8000 M and DM12000 M feature a motorized disk with 17 stops of various sizes, which are saved separately for every objective. This allows aperture openings from 5% to 100% to be approached enabling a 100% reproducibility of the imaging conditions. Together with the light intensity this aperture information is stored when saving an image and can be reproduced at any time. This high reproducibility is especially important for the review and classification of critical defects.

15. Illumination Manager

All Leica DM8000 M and DM12000 M inspection microscopes feature automatic Köhler light management. This fully integrated illumination control system detects the selected objective and automatically sets the user defined values for aperture and light intensity. This reduces inspection time and significantly supports less experienced operators. The user can change these illumination values according to the requirements of the sample at any time. The modified settings are automatically saved and used as the new default values.

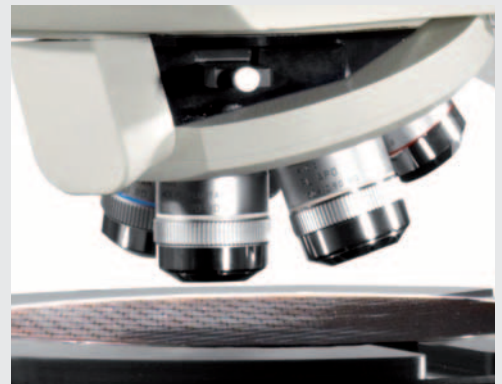

The illumination manager automatically adjusts intensity and aperture.

16. Contrast Manager

The contrast manager which is integrated in motorized (and semi-motorized) Leica DM8000 M or DM12000 M microscopes allows an easy and very fast change of the contrast mode: just press one of the programmable function buttons and all required adjustments of the light path for the selected contrast are automatically set. Toggle between brightfield and DF or have the UV and even the OUV contrast adjusted within less than a single second. This naturally covers more than just setting the appropriate reflector cubes on the integrated 4 position reflector turret; it also includes automatic adjustment of aperture diaphragm and light intensity.

17. Integrated Focus Finder

Easy focusing even on highly reflective surfaces, such as mirror-like bare wafers, is achieved with the integrated focus finder. With just a 90° rotation of the focus finder knob a round shaped diaphragm is inserted into the reflected light beam path. The correct focus position is easily found by focusing on the edge of the projected circle. Fast, easy and reliable.

18. Leica STP6000 SmartTouch Panel

The automated functions of the Leica DM8000 M or DM12000 M can be controlled directly on the microscope or on external remote devices provided by Leica such as a joystick for x, y control (incl. 4 additional function buttons), the Leica SmartMove for x, y and z control (incl. 4 additional function buttons) or the Leica STP6000 SmartTouch Panel for x, y and z control (incl. 12 additional function buttons). This selection provides a perfect match

of the user interface with the requirements of the individual inspection workflow.

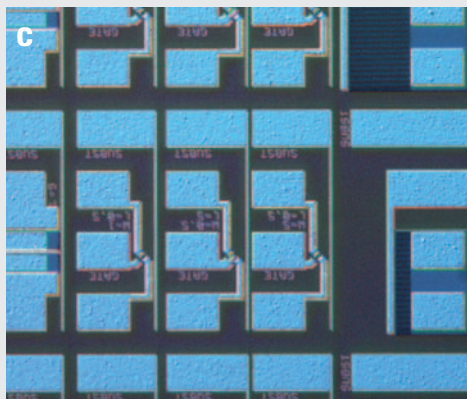
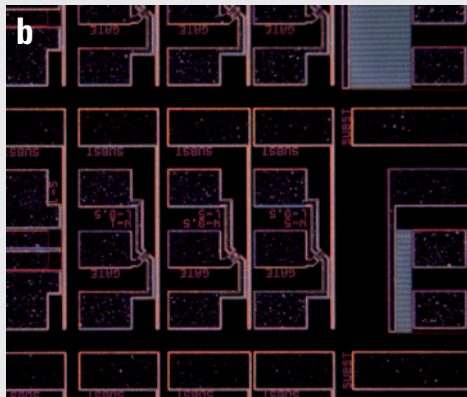
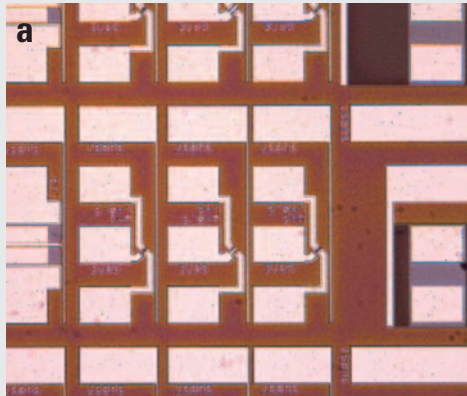

Accurate detection in all types of illumination: **(a)** brightfield, **(b)** in-depth darkfield, **(c)** DIC (Differential Interference Contrast). With the contrast manager of the motorized Leica DM8000 M or DM12000 M microscopes it takes less than a second to switch modes, and support operators with little experience using the system.

17.

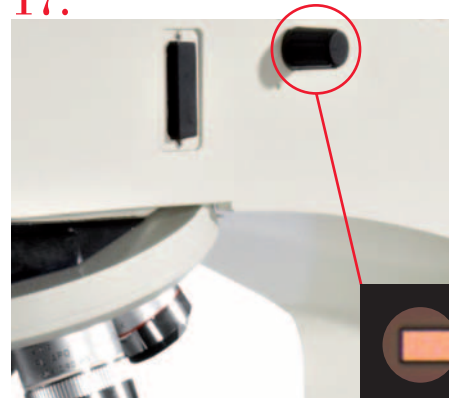

Easy focusing of even highly reflective surfaces with the focus finder

18.



The large, clearly arranged display of the Leica STP6000 shows all settings at a glance.

18.



Leica SmartMove remote control is used to control the x, y, and z settings.

Serving the Highest Standards

Protecting your investment and your samples

The innovative solutions incorporated into the Leica DM8000 M and DM12000 M go well beyond just the optical and mechanical performance of the inspection microscopes. Listening to our customers, we also integrated an innovative service concept, ESD protection and further measures allowing you to be compliant with the most important industrial standards.

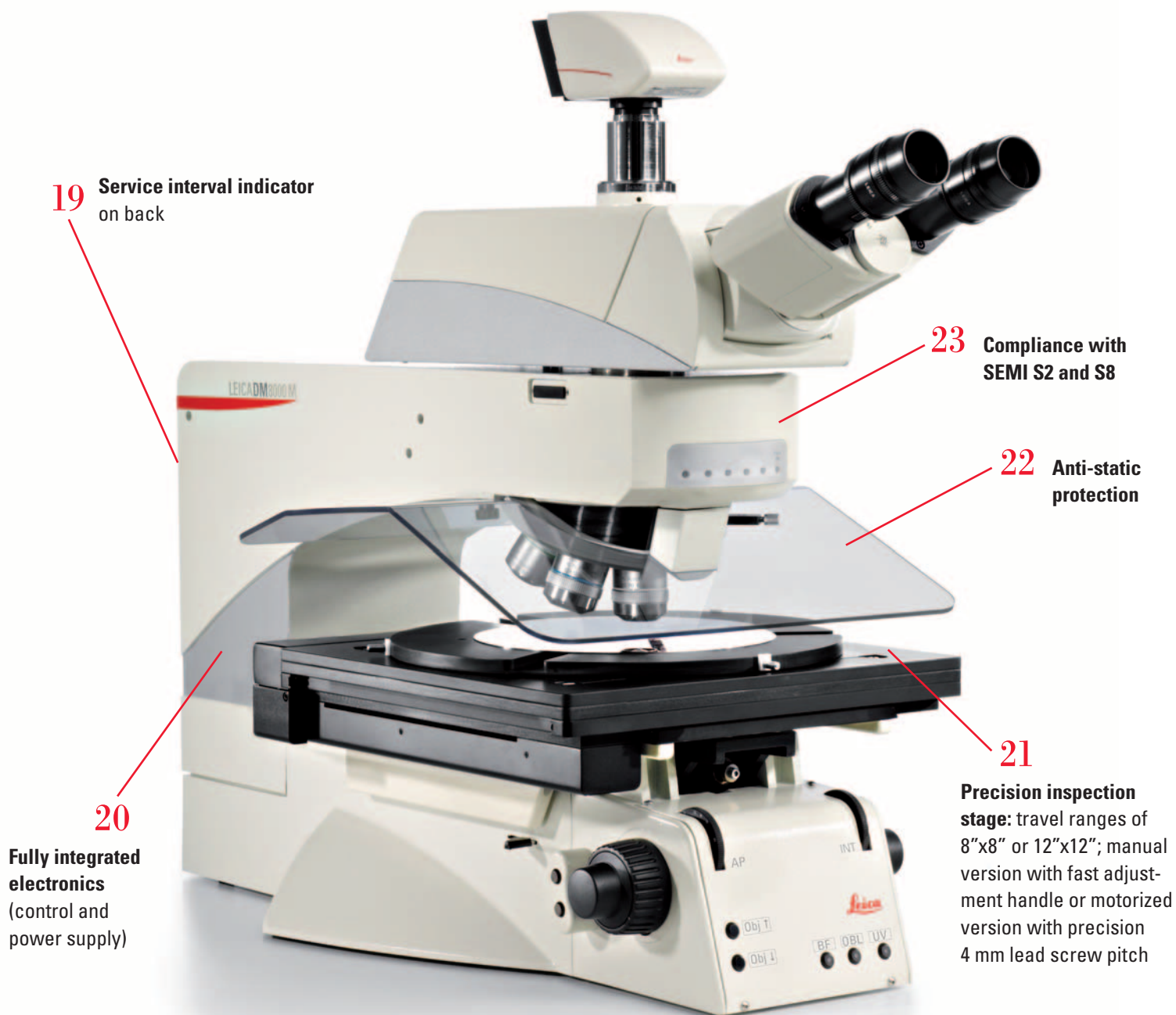

19. Service Interval Indicator

In addition to design features such as the long-life objective nosepiece or the integrated LED illumination the Leica DM8000 M and DM12000 M inspection microscopes support the user with information concerning the service status. A service-interval indication LED is integrated on the back of each 8" or 12" instrument.

This allows you to plan preventative maintenance well in advance and further reduces the risk of downtime of the instrument, even in very demanding applications.

20. Fully Integrated Electronics

The entire electronics required for control of nosepiece, illumination, contrasting and xyz movement for the LED illumination of TL and RL axis and also for the control of intensity and aperture are fully integrated into the stand of the microscope. Without the need for control boxes or power supplies the space around the inspection microscope is kept empty and clean.

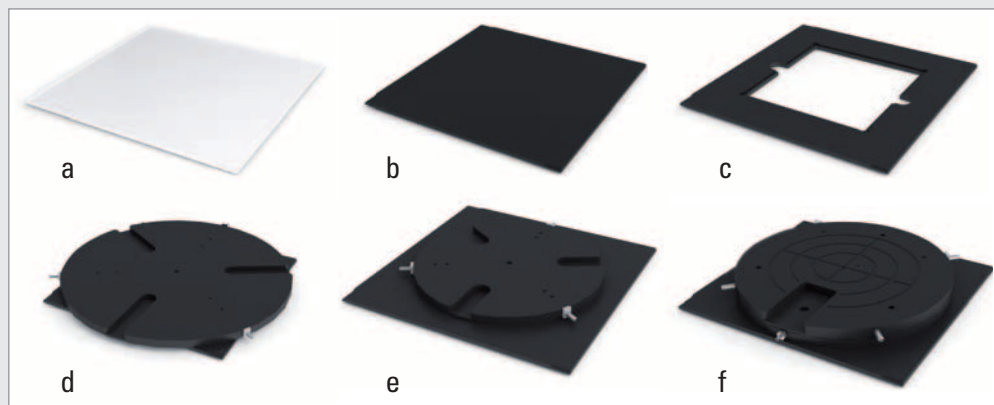

Glass plate (a), metal plate (b), mask holders in different sizes (c), 8-12" wafer holder (d), 6-8" wafer holder (e), 6-8" vacuum wafer holder (f)

21. Precision Inspection and Review Stages

Depending on the requirements and the sample size different stages are available. The manual 8" or 12" inspection stages are equipped with a fast adjustment handle. The positioning of the coaxial drive allows one-hand operation for the control of x, y and z movement.

Both the motorized 8" and 12" review stages feature a spindle drive with a ball screw pitch of 4 mm, allowing a fast travel speed of up to 240 mm/sec and at the same time a resolution of 0.01µm in x and y direction.

Using the motorized review stage, a point of interest selected in the Leica Application Suite (LAS) live image shown on the monitor is immediately positioned in the center of the field of view. For live image measurements or image analysis, this function is a key element.

A variety of different inserts for the manual and the motorized 8" or 12" stages is used depending on the size and the type of sample. Wafer holders (chucks) for 6-8" or for 8-12" diameters, both with or without vacuum fixation or mask holders, steel plates or glass plates – the user has a wide selection to choose from. Due to the same internal dimensions of the stages all inserts fit each stage and are fully interchangeable.

19.

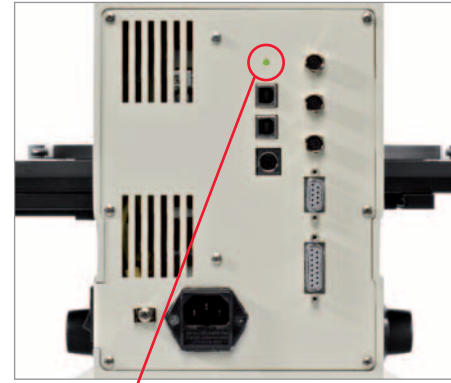

The service LED indicates the service status.

20.

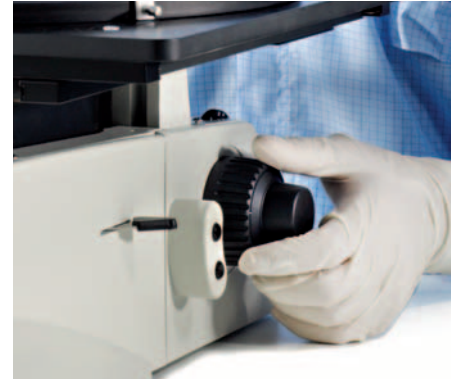

All control elements including electronics are integrated, leaving space around the microscope.

21.



High precision positioning with dedicated inspection stages

22.



Leica DM8000 M with contamination protection

22. Anti-static Protection

For the entire microscope frame including the tube or the optional adaptable contamination protection an antistatic coating is applied to prevent each type of microelectronic component being destroyed during inspection.

23. Compliance with SEMI S2 and S8

All Leica DM8000 M and DM12000 M inspection and review microscopes are in accordance with SEMI S2-0706 and SEMI S8-0705, CE and other industry standards. The assembly inside a cleanroom as well as special cleanroom packaging are keys for a high level of reliability of these systems in the same way as their ergonomic design or the integrated long-lifetime and safety precautions.

24. System Integration – Single-source Supply

With the Leica DM8000 M/DM12000 M, you have a complete system: the microscope, the Leica DFC camera and the Leica Application Suite (LAS) software are perfectly matched. Or upgrade the Leica DM8000 M/DM12000 M to an inspection system by choosing a wafer loader, matching accessories such as vacuum wafer chucks, and by installing a dedicated inspection software.



Fast but safe wafer handling is achieved with the adaptation of a wafer loader to the Leica DM8000 M, thus increasing the throughput of the system significantly. Different versions are combinable to the microscope ranging from load-only function to systems with integrated visual macro front- and back side inspection capabilities.

Selection Overview

	Leica DM8000 M manual focus	Leica DM8000 M motorized focus	Leica DM12000 M manual focus	Leica DM12000 M motorized focus
Contrast modes				
BF, OBL	+	+	+	+
DF, DIC	○	○	○	○
UV/OUV	○	○	○	○
Macro mode	–	○	–	○
LED illumination	+	+	+	+
Illumination manager	+	+	+	+
Contrast manager	○	+	○	+
Stage				
Manual version	+	○	+	○
Motorized (stage control integrated)		+		+
Stage control				
Joystick	–	○	–	○
Leica SmartMove	–	○	–	○
Leica STP6000	–	○	–	○
RL axis				
Manual contrast selection	+	○	+	○
Contrast manager	○	+	○	+
Focus finder	+	+	+	+
LED status display	○	+	○	+
6-position nosepiece mot., M32	+	+	+	+
TL axis				
LED illumination	+	+	+	+
Integrated polarizer	+	+	+	+
Tube				
Ergo trinocular tube w. upright image	○	○	○	○
Fixed trinocular tube w. upright image	○	○	○	○
Focus				
3-gear manual focus drive	+	–	+	–
Electronic focus drive	–	+	–	+
Height adjustable knobs	+	–	+	–
Parfocality adjustment	–	+	–	+

+ integrated as standard

○ optional

– not available

Technical Specifications

Systems	Leica DM8000 M	Leica DM12000 M
Optical systems	HC optics (infinity corrected optical system)	
Observation tube	Trinocular ergo tube with image erection Switching positions (eyepiece/camera): 100/0% and 0/100% 100/0% and 50/50%	
Macro imaging	Super-widefield overview image of up to 40 mm of the sample*	
Illumination system	Reflected light illumination system with LED; observation methods: brightfield, darkfield, DIC, qualitative POL, oblique, UV, OUV Integrated automatic aperture diaphragm Transmitted light illumination system with LED; observation methods: brightfield, qualitative POL 4-position reflector turret (manual/motorized use)	
Status feedback	Front status display* Service interval indicator (on back)	
Support systems	Integrated light manager Integrated contrast manager*	
Revolving nosepiece	Motorized, brightfield/darkfield (M32), 6-positions with slider slot for DIC Magnification change via front side control panel or external remote control unit (Joystick, Leica SmartMove, Leica STP6000)	
Stages	Manual inspection stage 8 x 8" ; 202 x 202 mm travel range, fast adjustment handle; for reflected and transmitted light observation	Manual inspection stage 12 x 12" ; 302 x 302 mm travel range, fast adjustment handle; for reflected and transmitted light observation
	Scanning stage 8 x 8" ; 202 x 202 mm travel range, motorized, 4 mm spindle pitch; for reflected and transmitted light observation*	Scanning stage 12 x 12" ; 302 x 302 mm travel range, motorized, 4 mm spindle pitch; for reflected and transmitted light observation*
	Repeatability*: < 1 µm (bi-directional, measured according to VDI / DGQ 3441) Accuracy: +/- 5 µm Resolution: 0.01 µm (smallest step size) Orthogonality: < 10 arc sec Max. travel speed: 240 mm/s, 4 mm ball screw pitch	
Stage inserts	6–8" wafer holder w/wo vacuum, 8–12" wafer holder w/wo vacuum, mask holders, RL plate, glass plate	
Control units	Joystick with 4 freely programmable positions Leica SmartMove, x, y, z control with 4 freely programmable positions Leica STP6000 SmartTouch x, y, z control with full remote control of instrument	
Focusing mechanism	High rigidity manual 2-gear focus; 35 mm stroke; height adjustable focusing knobs High precision manual 3-gear focus; 35 mm stroke; height adjustable focusing knobs Motorized 2-gear focus; 35 mm stroke; high repeatability; parfocality adjustment	
Electrical system	Input rating: 100–120/220–240 V AC, 50/60 Hz, P max = 100 W	
Weight	approx. 41 kg (microscope approx. 29 kg)	approx. 52 kg (microscope approx. 31 kg)
Operation environment	For use in industrial environment for EMC performance (class A device). Use in residential environment may affect other equipment in the environment Amb. temperature: 15°C–35°C Relative humidity: 80% for temperatures up to 33°C (without condensation) Supply voltage fluctuations: +/- 10% Installation (overvoltage) category: II ref. IEC60664 Pollution degree: 2 ref. IEC60664	

Dimensions (in mm)

Leica DM8000 M

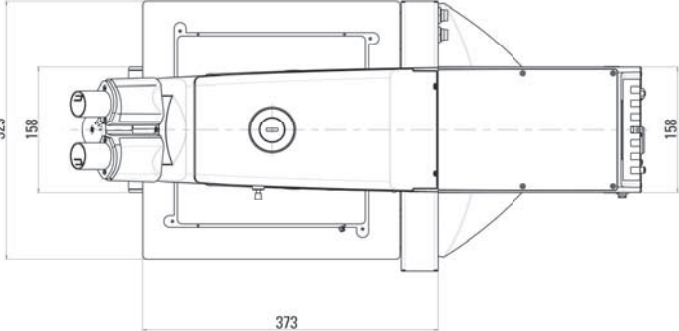
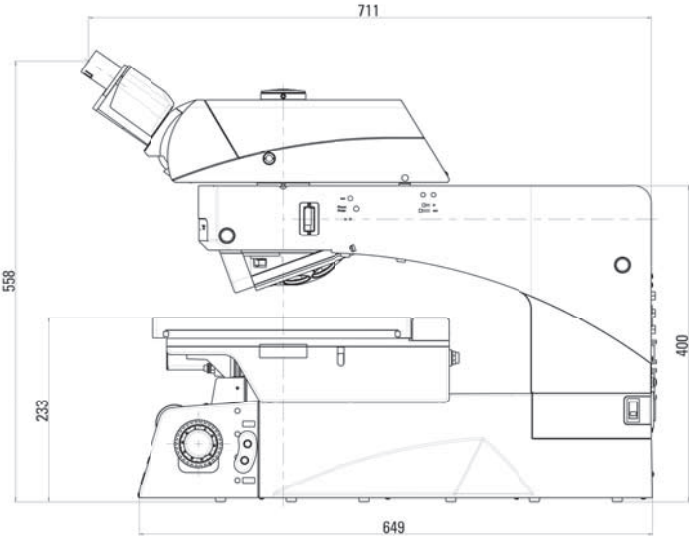

Leica DM12000 M

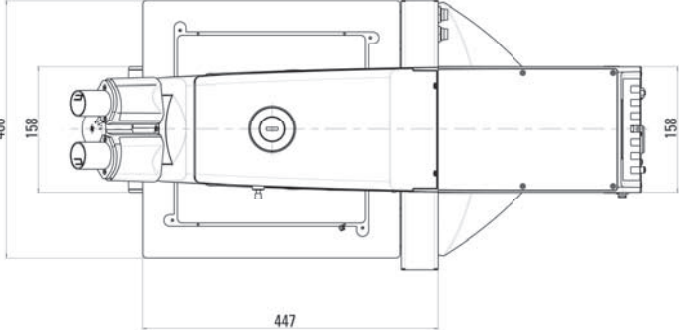
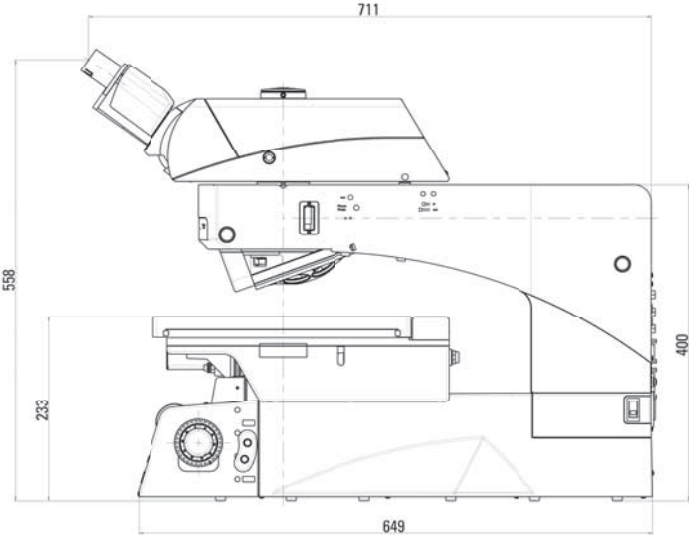

System Overview

Leica DM8000 M

Leica DM12000 M

Status: May 2011

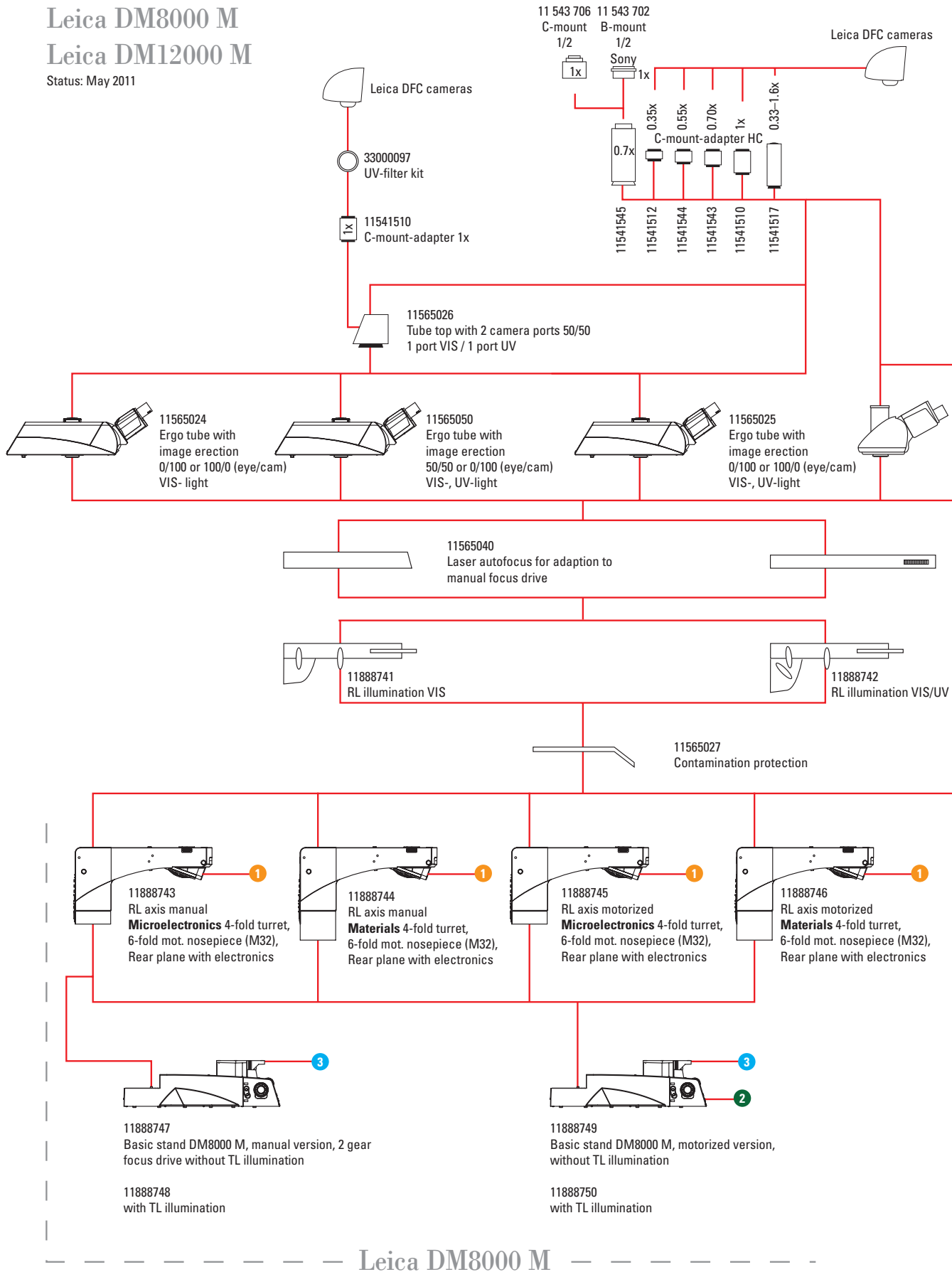

11501598
Fixed tube 20° with image erection
0/100 or 100/0 (eye/cam)
VIS-light

Tubes
Leica DM1000-6000

11505252
Manual magnification changer, VIS
1x, 1.5x, 2x

1 Special objectives

- 11888763 Macro overview
- 11566204 PL APO 150x/0.95 IVIS BD

2 Remote controls

- 11565041 Joystick Remote control

- 11505180 Leica SmartMove Remote control

- 11501255 Leica STP6000 Remote control

3 8" stages

- 11888755 Manual 8" stage with fast adjustment handle
- 11888757 8" Scanning stage

4 12" stages

- 11888756 Manual 12" stage with fast adjustment handle
- 11888758 12" Scanning stage

5 Inserts and holders

- Wafer chuck, manual with vacuum 11565035 8"-12"

- Wafer chuck, manual with vacuum 11565034 6"-8"

- 11565036 Glass stage insert

- Wafer chuck, manual 11565033 8"-12"

- Wafer chuck, manual 11565031 5"-6"
- 11565032 6"-8"

- 11565029 Metal stage insert

- Mask holder 11565037 4" x 4"
- 11565038 5" x 5"

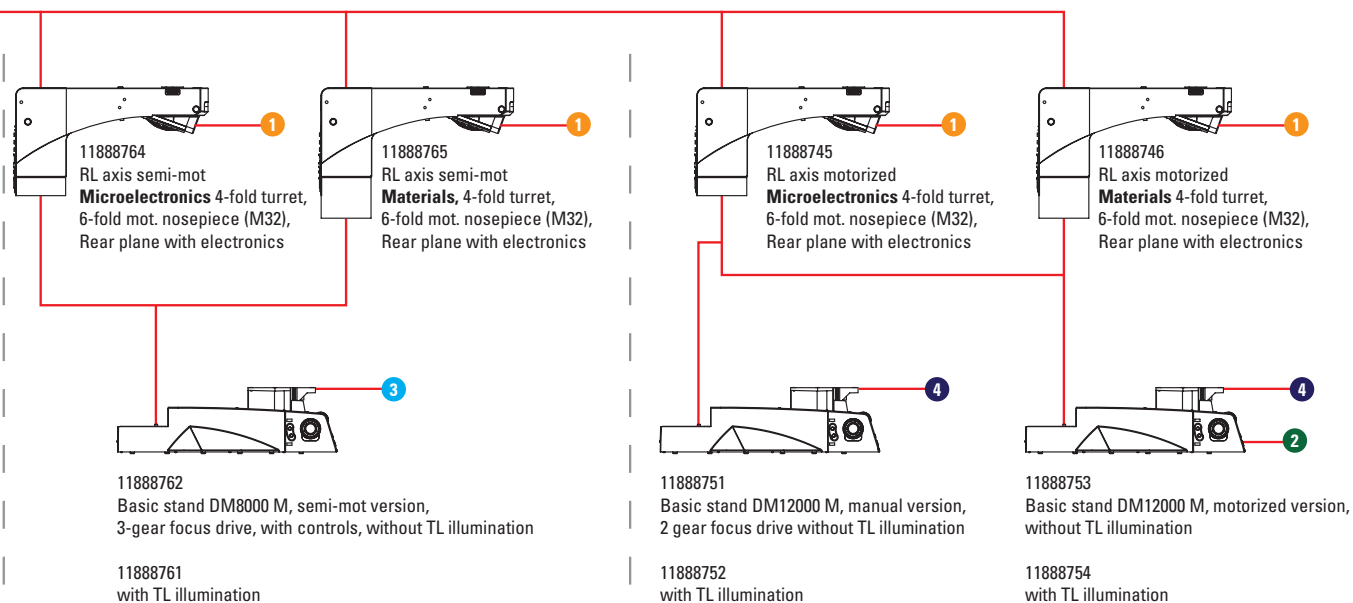

— Leica DM8000 M semi mot —

— Leica DM12000 M —

“With the user, for the user”

Leica Microsystems

Leica Microsystems operates globally in four divisions, where we rank with the market leaders.

• Life Science Division

The Leica Microsystems Life Science Division supports the imaging needs of the scientific community with advanced innovation and technical expertise for the visualization, measurement, and analysis of microstructures. Our strong focus on understanding scientific applications puts Leica Microsystems' customers at the leading edge of science.

• Industry Division

The Leica Microsystems Industry Division's focus is to support customers' pursuit of the highest quality end result. Leica Microsystems provide the best and most innovative imaging systems to see, measure, and analyze the microstructures in routine and research industrial applications, materials science, quality control, forensic science investigation, and educational applications.

• Biosystems Division

The Leica Microsystems Biosystems Division brings histopathology labs and researchers the highest-quality, most comprehensive product range. From patient to pathologist, the range includes the ideal product for each histology step and high-productivity workflow solutions for the entire lab. With complete histology systems featuring innovative automation and Novocastra™ reagents, Leica Microsystems creates better patient care through rapid turnaround, diagnostic confidence, and close customer collaboration.

• Medical Division

The Leica Microsystems Medical Division's focus is to partner with and support surgeons and their care of patients with the highest-quality, most innovative surgical microscope technology today and into the future.

The statement by Ernst Leitz in 1907, “with the user, for the user,” describes the fruitful collaboration with end users and driving force of innovation at Leica Microsystems. We have developed five brand values to live up to this tradition: Pioneering, High-end Quality, Team Spirit, Dedication to Science, and Continuous Improvement. For us, living up to these values means: **Living up to Life.**

Active worldwide

Australia:	North Ryde	Tel. +61 2 8870 3500	Fax +61 2 9878 1055
Austria:	Vienna	Tel. +43 1 486 80 50 0	Fax +43 1 486 80 50 30
Belgium:	Groot Bijgaarden	Tel. +32 2 790 98 50	Fax +32 2 790 98 68
Canada:	Richmond Hill/Ontario	Tel. +1 905 762 2000	Fax +1 905 762 8937
Denmark:	Ballerup	Tel. +45 4454 0101	Fax +45 4454 0111
France:	Nanterre Cedex	Tel. +33 811 000 664	Fax +33 1 56 05 23 23
Germany:	Wetzlar	Tel. +49 64 41 29 40 00	Fax +49 64 41 29 41 55
Italy:	Milan	Tel. +39 02 574 861	Fax +39 02 574 03392
Japan:	Tokyo	Tel. +81 3 5421 2800	Fax +81 3 5421 2896
Korea:	Seoul	Tel. +82 2 514 65 43	Fax +82 2 514 65 48
Netherlands:	Rijswijk	Tel. +31 70 4132 100	Fax +31 70 4132 109
People's Rep. of China:	Hong Kong	Tel. +852 2564 6699	Fax +852 2564 4163
Portugal:	Lisbon	Tel. +351 21 388 9112	Fax +351 21 385 4668
Singapore		Tel. +65 6779 7823	Fax +65 6773 0628
Spain:	Barcelona	Tel. +34 93 494 95 30	Fax +34 93 494 95 32
Sweden:	Kista	Tel. +46 8 625 45 45	Fax +46 8 625 45 10
Switzerland:	Heerbrugg	Tel. +41 71 726 34 34	Fax +41 71 726 34 44
United Kingdom:	Milton Keynes	Tel. +44 800 298 2344	Fax +44 1908 246312
USA:	Buffalo Grove/Illinois	Tel. +1 847 405 0123	Fax +1 847 405 0164

and representatives in more than 100 countries